

# Ham Radio Solutions CW Hotline Assembly Manual

Version 0.51 2-9-2022



The Ham Radio Solutions CW Hotline is a fairly simple construction project that can usually be built in about two hours. You will need a low wattage pencil-type soldering iron with a small tip, some thin solder, a pair of diagonal cutters and a Phillips head screwdriver. Desoldering braid may be required to correct soldering mistakes. Be sure to wear eye protection when soldering and cutting leads.

Most parts, except for a few at the end, should be inserted into the side of the PCB with the jack silkscreens J1, J2, J6. Unless otherwise indicated, parts should be flush with the PCB. After inserting, turn the board over and solder the leads to the pads on the other side. It is often helpful to just solder one lead, then ensure the component is correctly positioned before soldering the remaining leads. Be sure to only solder the correct pads, and do not let any solder touch any other pad or trace. Trim any excess leads with diagonal cutters after soldering each batch of components. The checklist will be useful to ensure all components are properly assembled.

Build slowly and follow the instructions. Use the images to confirm component placement. CW Hotline may be built with a straight key, lambic paddles, or neither. It is recommended to drill the case first, then use the case to aid in placing some components on the PCB.

## Schematic

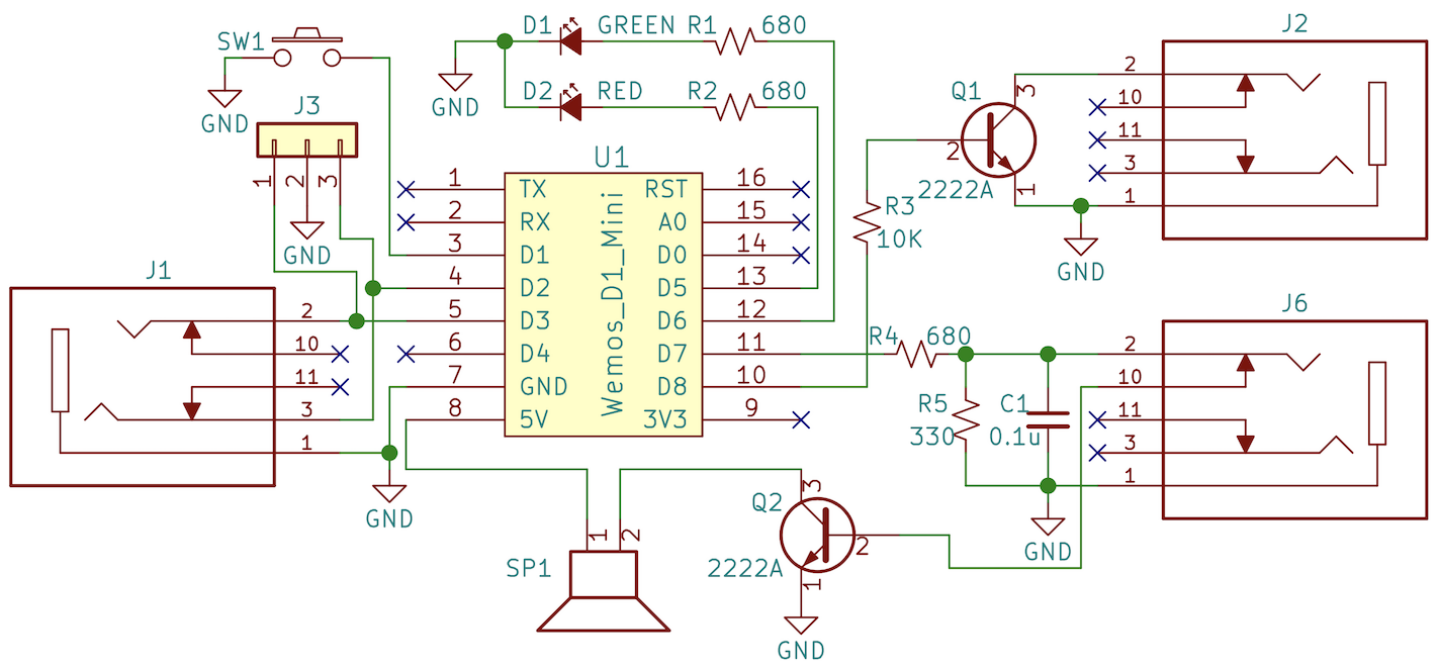

CW Hotline includes a case, but it must have holes drilled and cut. A drilling template should be printed out at 100% size. Don't print with "Fit to page".

### Case Parts

- CW Hotline case
- Printed case drilling / cutting template
- 4 - M2.6 x 8mm black screws
- Vinyl label

### Case Tools Needed

- Scissors
- Tape
- X-acto knife / Safety pin
- Drill with 5/64", 1/8", 5/32" 1/4" (2mm, 3mm, 4mm, 6mm) drill bits
- Emery board



### Case Assembly

- Measure the 1" or 2 cm reference square on the template to ensure it was printed at the proper scale.
- Cut out the template cross shape on the outer solid lines.
- Remove the thin bottom plate of the case and set it aside. Wrap the template around the outside of the case such that the 4 edges of the template just reach the edges of the case. Use tape to secure the template to the case.
- Use a safety pin or knife tip to mark/dimple the centers of the holes. There are 10 holes on the top, 3 on the long side, and 2 overlapping holes on the short side.
- If including the straight key or paddles on the PCB, use an X-acto knife to mark the location of the rectangular hole on the other short case side, along the dotted lines.
- Remove the template and tape. The template will help to reference hole sizes.
- Drill out all 15 holes with the 5/64" / 2mm drill bit.
- Enlarge the LED, button, and side holes with the 1/8" / 3mm drill bit. Do not enlarge the 7 speaker holes.
- Enlarge the button and side holes with a 5/32" / 4mm drill bit. Do not enlarge the other top holes.
- Enlarge the 5 side holes with the 1/4" / 6mm drill bit. To avoid cracking the case, step up through multiple intermediate bit sizes 1/32" / 1mm at a time or use a step bit.
- Use an X-acto knife to convert the 2 holes on the short side to an oval that will accept the USB cable. A Rat tail file may help.
- If including the straight key or paddles on the PCB, use an X-acto knife, hacksaw, or nibbler tool to remove the rectangular hole on the case side. Be careful with this step! Sewing thread can also work as a cord saw. Smooth with a file or emery board.

### After PCB is assembled (see instructions below)

- Enlarge holes as necessary to fit the PCB into the case.
- Secure PCB to case with 4 screws in the corner holes. Do not over tighten or the plastic may crack.
- Close case with the removed plate, with the notched end near the rectangular hole.
- Apply vinyl label.



## PCB Parts

- PCB - CW Hotline Printed Circuit Board
- R1, R2, R4 - 680 ohm resistors (blue-grey-brown)
- R3 - 10K ohm resistor (brown-black-orange)
- R5 - 330 ohm resistor (orange-orange-brown)
- C1 - 0.1uf capacitor (marked 104)
- Q1, Q2 - 2222A NPN transistors
- J1, J2, J6 - 3.5mm stereo TRS jacks
- 2 1x8 male header posts for ESP8266
- ESP8266 in WeMos D1 mini form factor, programmed with CW Hotline firmware
- D1 - green 3MM LED
- D2 - red 3MM LED
- SW1 - SPST momentary button
- 1 small speaker
- 1 small piece foam tape
- 1 MicroUSB cable

## PCB Assembly

- Install resistors R1, R2, & R4. For each resistor, bend the leads near the bulb 90 degrees and parallel and insert into the PCB. Orientation is not important.
- Install resistors R3 & R5 as resistors above.
- Install capacitor C1. Orientation is not important.
- Install transistors Q1 & Q2. Be sure to match the orientation with the flat side on the silkscreen. Leads are often very close together so do not let solder contact between any 2 leads.
- Install stereo jacks J1, J2, J6. Ensure all jacks are flush with the PCB.
- Install 2 1x8 male header posts into PCB. Insert the short sides of the post in the PCB holes. Solder just one pin each on the other side of the PCB, ensure the pins are perpendicular and flush with the PCB, temporarily test fit the blue ESP8266 PCB, and then solder the remaining pins. Use standard ESD precautions when handling the ESP8266 PCB. If you do not have a grounding strap, touch a large piece of metal before touching the ESP8266 PCB.
- Insert the blue ESP8266 PCB onto the long sides of the previous header posts, being sure to match the silk screen orientation, with the reset button nearest the upper left corner. Solder only two diagonally opposite pins to the hole on the top face of the blue ESP8266 PCB and verify the board is flush. Solder the remaining pins. Do not trim the remaining exposed posts.
- Insert the green LED D1 onto **the other side of the PCB**. The shorter lead, nearest the flat side of the LED, should go into the square hole. **The LED should not be flush with the PCB**, but instead a 5/32" or 4mm gap between the PCB and the bottom of the LED. If the case has been drilled, you can fit the LED and PCB in the case to set the position for the LEDs to slightly protrude. Solder just one lead and adjust until the spacing is correct, then solder the other lead.
- Insert the red LED D2 the same way as D1.
- Insert button SW1 on the same side of the PCB as the LEDs. It should only fit one way and the 2 middle pads will not be used. **The button should not be flush with the PCB**, but instead 1/32" or 1mm gap between the PCB and the bottom of the button.



- Install the speaker leads into pads marked SP1. If the speaker has a connector on the end of the leads, remove it and strip the insulation. The red wire should go to the square hole. Solder on the other side. Use the small square of double sided foam tape to stick the speaker to the PCB above the circle. Decide if the CW Hotline should be built with a straight key or lambic paddles and follow the corresponding instructions. If it will be only used with external keys and paddles, both instructions may be disregarded.

### Straight Key Parts

- 1 Straight Key PCB arm
- 1 PCB wrench for #4 nuts
- 3 #4-40 3/8" screws
- 2 #4 washers
- 7 #4 nuts
- 1 knob & cap
- 1 #4-40 5/8" screw



### Straight Key Assembly

- Insert 2 3/8" screws into the 2 holes nearest the center of the main PCB with the screw heads on the LED side of the PCB. On the other side, insert a #4 washer and nut onto each screw and hand tighten. Note that the kit includes two #4 washers and one larger #6 washer. The #6 washer is for use with the paddle.
- Insert the last 3/8" screw into the hole nearest the center of the PCB arm, and lightly secure with a nut.
- Insert the PCB arm onto the main PCB on the ESP8266 side through the 2 first screws, with the third screw through the PCB hole marked GND. Secure to the first 2 screws with 2 nuts.
- Add the final nut to the third screw on the LED side of the PCB. This screw should be rigidly secured to the main PCB, and the screw head should only make contact with the plated ring around the hole on the arm when the arm is pressed. Using the PCB wrench, adjust the 2 nuts on the screw so the head of the screw is just below but doesn't contact the ring on the PCB arm.
- Insert the 5/8" screw to the last hole in the PCB arm with the head on the ESP8266 side. Remove the cap from the knob, add the knob to the other side, and secure with the last nut. Place the cap back on the knob.

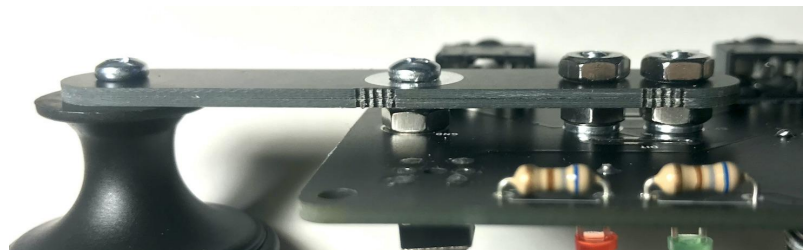

## Paddle Parts

- 2 Paddle PCB arms (1 left, 1 right)
- 2 #4-40 3/16" screws
- 1 13/32" #4-40 hex standoff (10.3mm long)
- 1 #4-40 3/8" screws
- 1 #6 steel washer (9.8mm x 1.1mm thick)
- 2 #4 nuts

## Paddle Assembly

- Separate the paddle arms from each other and lightly sand or file the edge where they were connected.
- Connect the paddle arms to each other using the hex standoff to create the spacing. Be sure the paddle arm text is on the outside, the exposed contact pads are on the inside facing each other. Use the two 3/16" screws through the two large holes in the paddle arm corners.
- Insert the paddle arms tabs into the main PCB on the jack side.
- Solder just one corner of one of the arm tabs on the LED side of the main PCB, ensuring the arm is parallel with but doesn't contact the main PCB except at the soldering pad. Once it is in position, solder the rest of the tab.
- Solder the other arm in a similar manner.
- Install the larger #6 washer to the 3/8" screw and secure with a nut. This washer will be the contact point for both paddle arm pads.
- Insert that screw into the hole on the main PCB marked GND with the washer between the paddle arms. Secure on the other side of the PCB with a nut.
- Adjust and rotate the washer so that it is equally spaced between the paddle arms.
- Optionally push or pull the arms slightly while melting the solder to fine tune the arm spacing.

